

South Elevation - Sidewalk Looking North

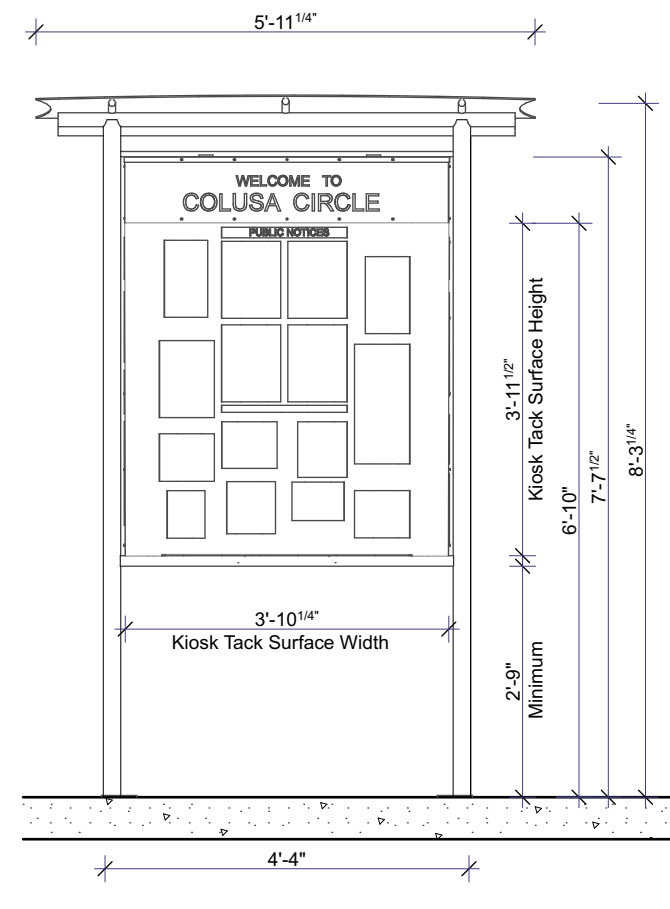

Front Elevation- Sidewalk View

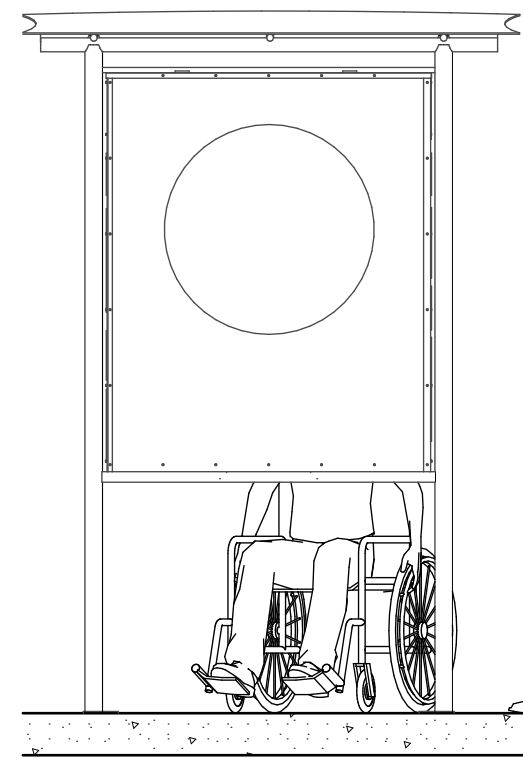

Rear Elevation - Street View

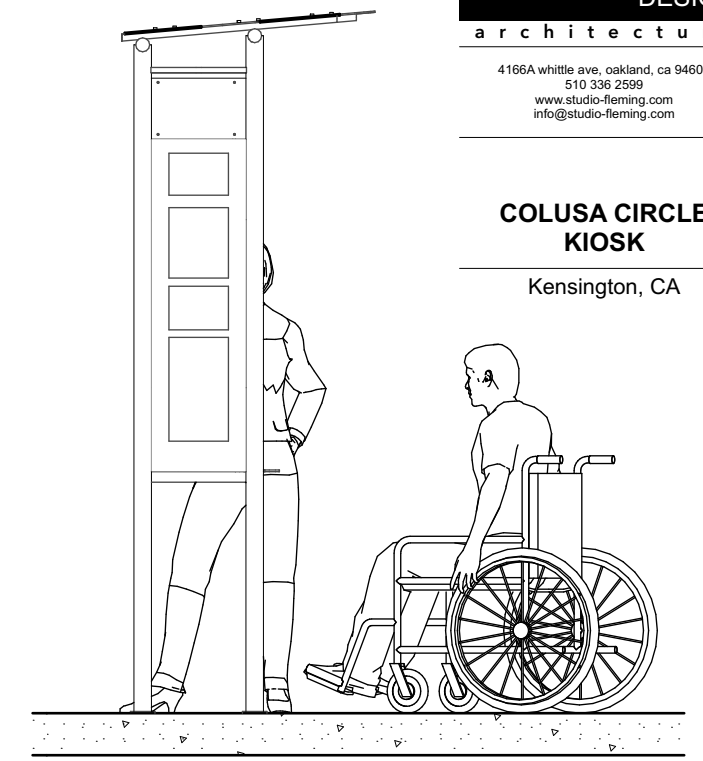

North Elevation - Sidewalk Looking South

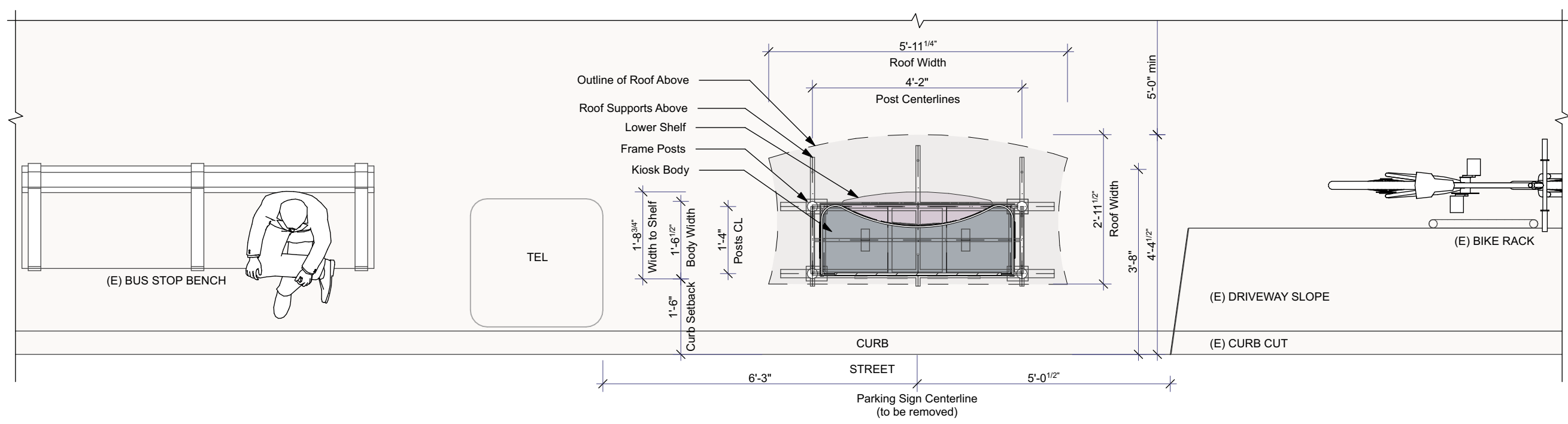

Kiosk Sidewalk Plan View

date: 2/5/20  
scale: 1/4" = 1'-0"  
ID:      date:      revision:

OWNERSHIP AND USE OF DOCUMENTS  
All Drawings, Specifications and copies thereof furnished by studioFleming design are and shall remain its property. They are to be used only with respect to this Project and are not to be used on any other project. Submission or distribution to meet official regulatory requirements or for purposes in connection with the Project is not to be construed as publication in derogation of studioFleming design common law copyright or other reserved rights.

COLUSA CIRCLE  
KIOSK  
Kensington, CA



date: 2/5/20  
scale: 1/4" = 1'-0"  
ID:      date:      revision:

OWNERSHIP AND USE OF DOCUMENTS  
All Drawings, Specifications and copies thereof furnished by studioFleming design are and shall remain its property. They are to be used only with respect to this Project and are not to be used on any other project. Submission or distribution to meet official regulatory requirements or for purposes in connection with the Project is not to be construed as publication in derogation of studioFleming design common law copyright or other reserved rights.

Front Sidewalk View

Sidewalk Elevation



Rear Street View

COLUSA CIRCLE  
KIOSK

Kensington, CA

date: 2/5/20  
scale: 1/4" = 1'-0"

ID:      date:      revision:

OWNERSHIP AND USE OF DOCUMENTS  
All Drawings, Specifications and copies thereof furnished by studiofleming design are and shall remain its property. They are to be used only with respect to this Project and are not to be used on any other project. Submission or distribution to meet official regulatory requirements or for purposes in connection with the Project is not to be construed as publication in derogation of studiofleming design common law copyright or other reserved rights.

Street Elevation

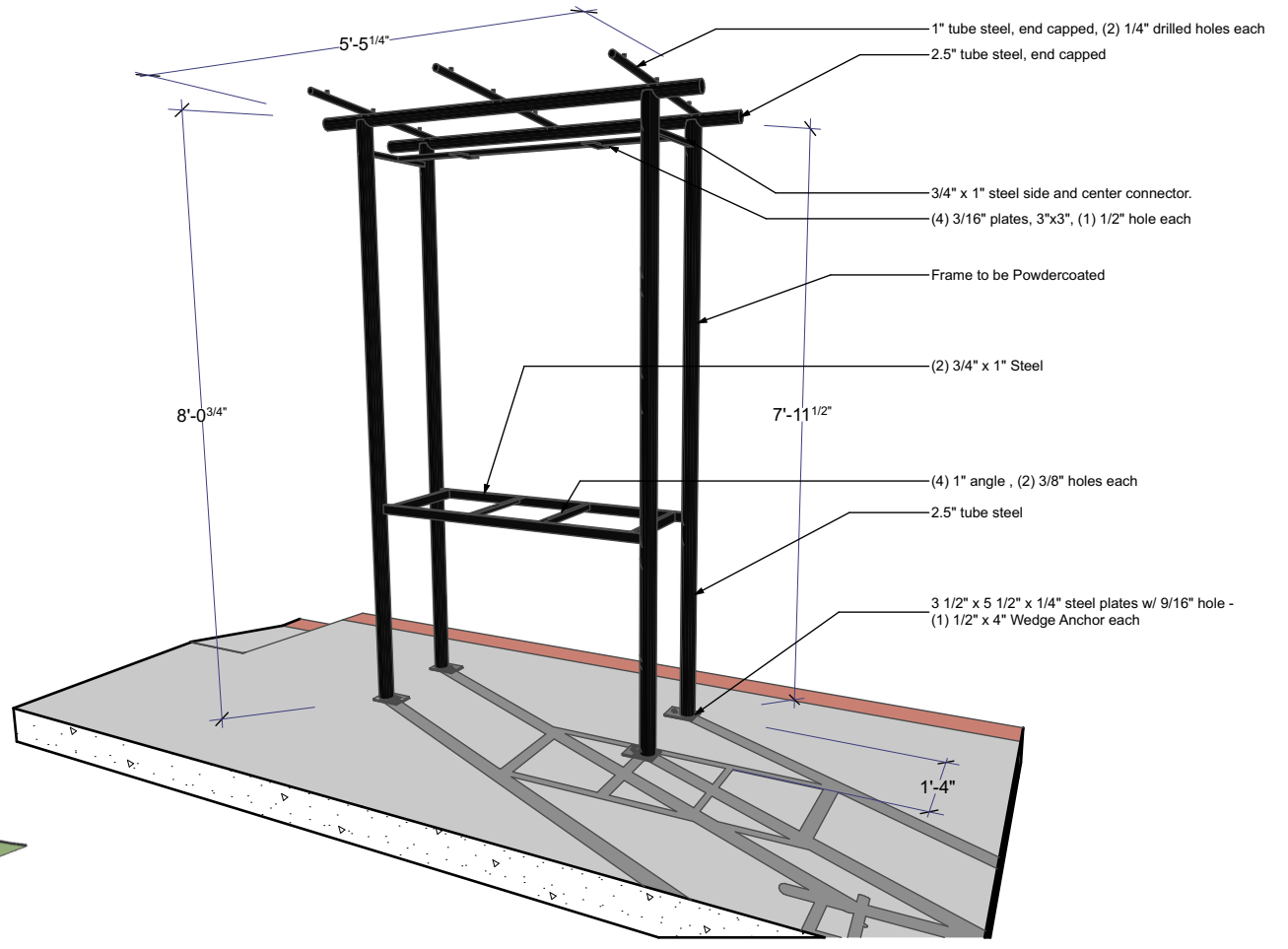
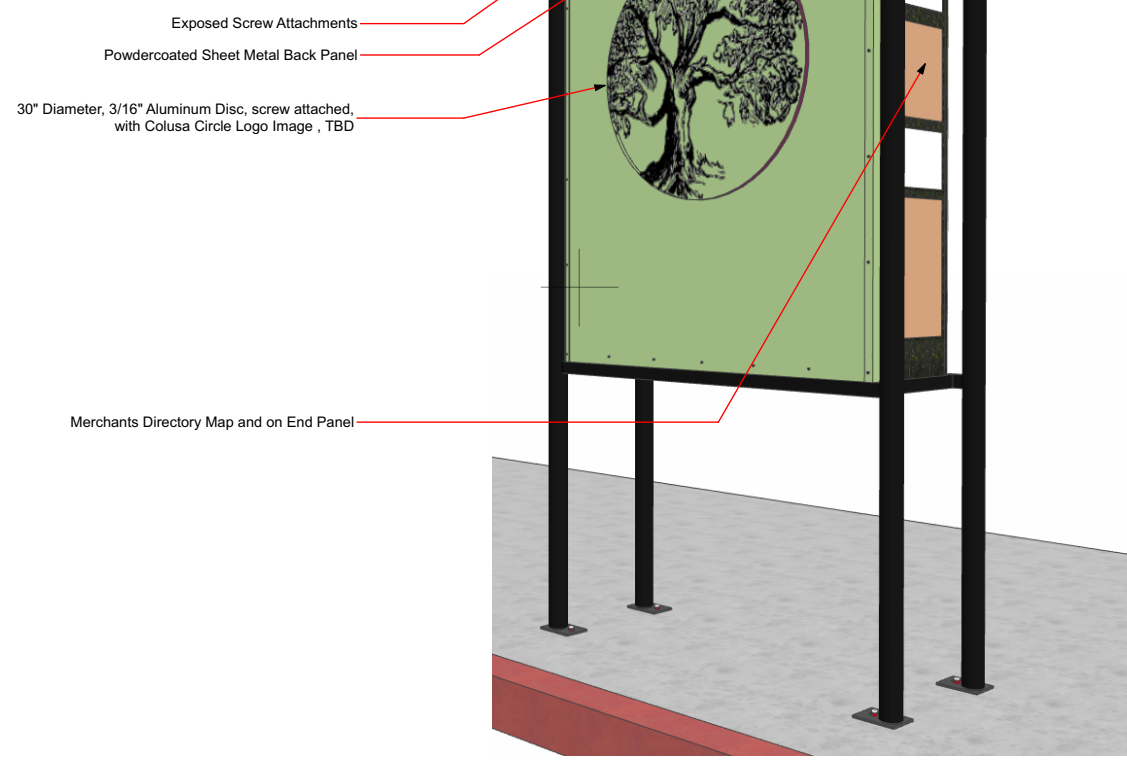
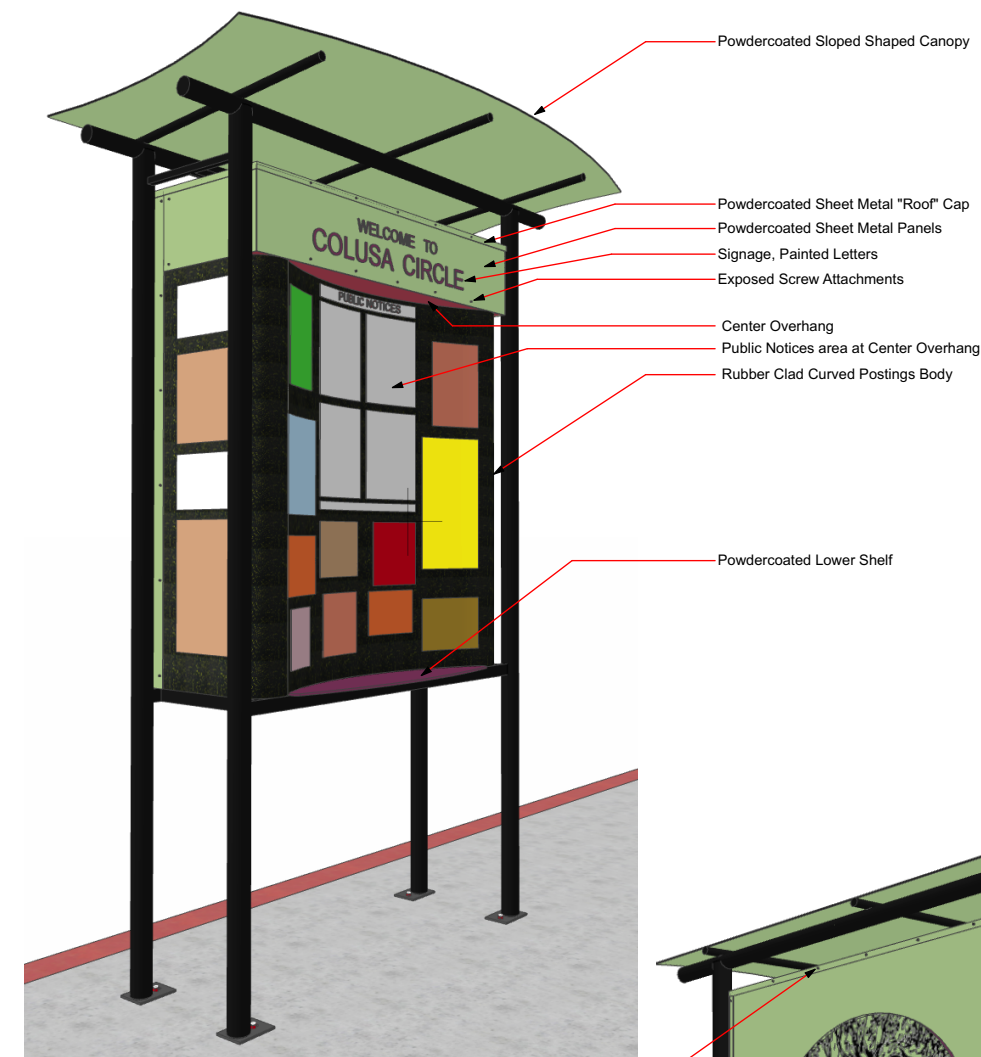

1 Kiosk Frame Only

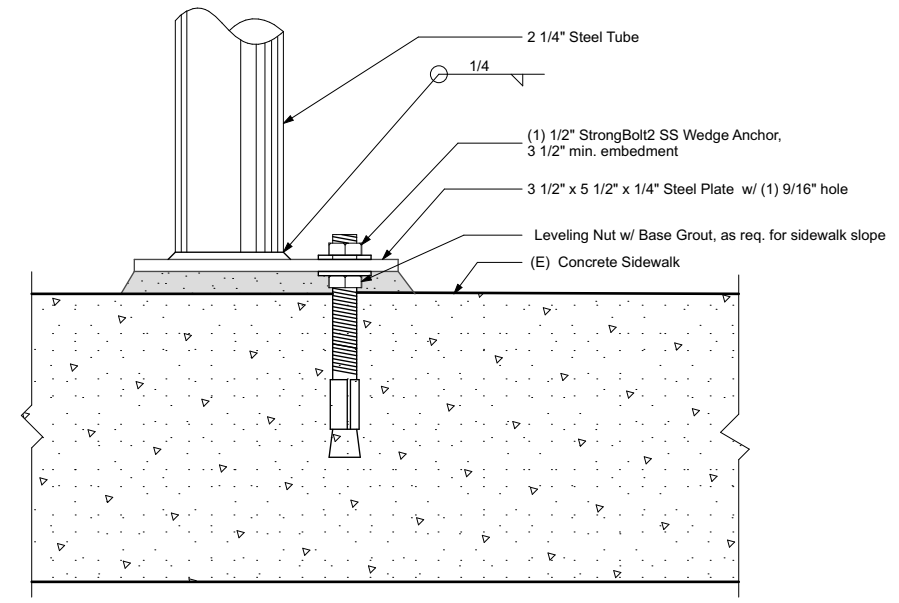

2 Frame Attachment Detail

date: 2/5/20  
scale: 1/4" = 1'-0"

ID:      date:      revision:

OWNERSHIP AND USE OF DOCUMENTS  
All Drawings, Specifications and copies thereof furnished by studio-fleming design are and shall remain its property. They are to be used only with respect to this Project and are not to be used on any other project. Submission or distribution to meet official regulatory requirements or for purposes in connection with the Project is not to be construed as publication in derogation of studio-fleming design common law copyright or other reserved rights.

Frame Details

COLUSA CIRCLE  
KIOSK

Kensington, CA



date: 2/5/20  
scale: 1/4" = 1'-0"

ID:      date:      revision:

OWNERSHIP AND USE OF DOCUMENTS  
All Drawings, Specifications and copies thereof furnished by studioFleming design are and shall remain its property. They are to be used only with respect to this Project and are not to be used on any other project. Submission or distribution to meet official regulatory requirements or for purposes in connection with the Project is not to be construed as publication in derogation of studioFleming design common law copyright or other reserved rights.

Sidewalk Looking South

North Elevation

COLUSA CIRCLE  
KIOSK

Kensington, CA



date: 2/5/20  
scale: 1/4" = 1'-0"

ID:      date:      revision:

OWNERSHIP AND USE OF DOCUMENTS  
All Drawings, Specifications and copies thereof furnished by studioFleming design are and shall remain its property. They are to be used only with respect to this Project and are not to be used on any other project. Submission or distribution to meet official regulatory requirements or for purposes in connection with the Project is not to be construed as publication in derogation of studioFleming design common law copyright or other reserved rights.

Sidewalk Looking North

South Elevation